

AstroFan™ EC FFU

FAN FILTER UNIT

Product Overview

- Top-side serviceable or room-side replaceable and serviceable (Room side replaceable and serviceable option includes aerosol injection and static-pressure ports)
- Energy-efficient EC motor (brushless, DC) provides 30-40% savings in energy use compared to AC alternatives
- Whisper-quiet operation compared to AC alternatives
- Multiple control options allow large-scale integrated operational control
- Highest efficiency airflow rates when coupled with AAF Flanders' eFRM or ePTFE filtration media technology
- Five standard sizes: 2x2, 2x3, 2x4, 3x4, and 4x4 (custom sizes available)

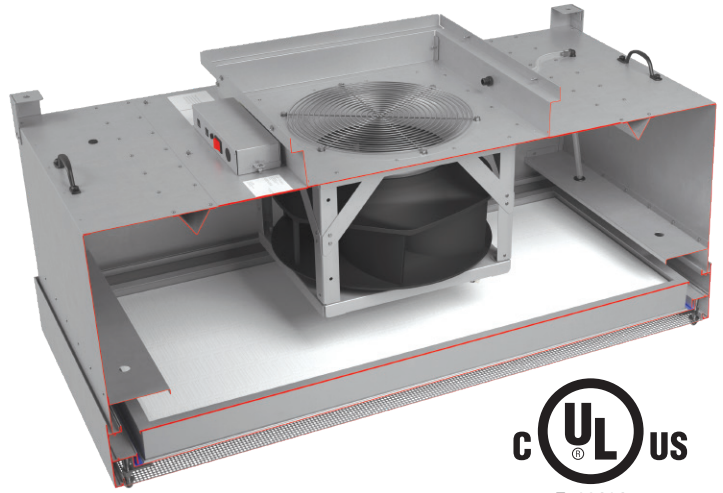

Application and Installation Considerations

AstroFan EC Fan Filter Units are ideal for use in all applications requiring controlled clean air, particularly cleanrooms supporting:

- Microelectronic fabrication
- Semiconductor manufacturing
- Medical device manufacturing and assembly
- Pharmaceutical processing
- Sterile compounding pharmacies
- Hazardous drug and/or material handling
- All other regimented and regulated applications

Units can be serviced from either top-side or room-side. Filters can be replaced and aerosol tested to meet validation requirements from the room-side with appropriate configuration.

Coupled with AAF Flanders' eFRM or ePTFE HEPA and ULPA Filtration technologies, the AstroFan EC FFU units offer the most energy efficient and quiet option available today. The AstroFan EC FFU is suitable for open plenum as well as ducted arrangements and can be controlled via handheld or wall-mounted control options.

Specifications

Casing Material	Aluminum or 304 SST
Fan	Backward Curved Centrifugal Blower
Motor	EC, 50/60 Hz, 1-Phase
Voltages	100V - 130V 200V - 277V
Max Flow Rates*	
2x2 to 2x3	1200 CFM/2040 CMH
2x4 to 4x4	2000 CFM/2400 CMH
Operating Temp	25°F to 115°F

* Less Filter

Options

Inlet Duct Collar	Round or Rectangular
Pre-filter Frame	Particulate or AMC
Painted Housing	White Powder Coat
Insulation	2" Foilback

AstroFan™ EC FFU

Certain applications require unit-specific control of the speed and consistency of airflow into large-scale production spaces. Fan Filter Units, especially when paired with eFRM or ePTFE media and AstroDrive™ controls, help to ensure the integrity of production processes within these applications and serve to maximize the overall system economy.

AstroFan EC FFU

Selecting the right FFU depends on several factors, including the degree of airflow control required, the desired level of energy efficiency, filter testing requirements for the space, and accessibility to the filter itself for testing and replacement.

The AstroFan EC Fan Filter Units deliver:

- Top-side serviceable or room-side replaceable and serviceable minimizes cleanroom service and downtime
- Energy-efficient EC motor (brushless, DC) provides 30-40% savings in energy use compared to AC alternatives, resulting in significantly lower operating costs.
- Whisper-quiet technology meets stringent noise suppression requirements
- Multiple control options allow for large-scale integrated operation
- Highest efficiency airflow rates, when coupled with MEGAcel® II eFRM or ePTFE filters, minimizes energy consumption
- Five standard sizes: 2x2, 2x3, 2x4, 3x4, and 4x4 (custom sizes available)

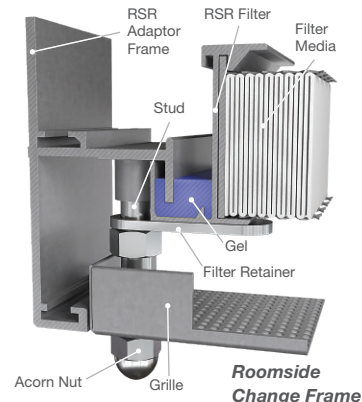
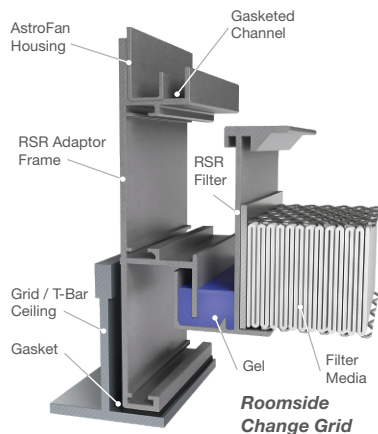
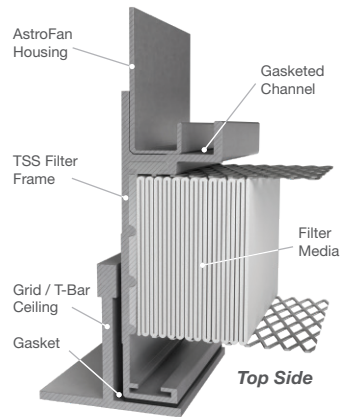

MEGAcel II HEPA and ULPA Filtration

The strength of the filter material is critical to the success of a cleanroom environment. Depending on the carrier substrate, the strength of MEGAcel II eFRM and ePTFE filters is up to 100 times stronger than microglass. eFRM and ePTFE membrane media do not fail under standard operating procedures, cleaning, installing, or testing, and provide durability to mitigate almost all risks of contamination from airflow. MEGAcel II HEPA/ULPA filters utilizing Daikin's ultra-fine fiber membrane media are the product of choice in the most demanding environments.

MEGAcel II eFRM Media:

Dual layers of expanded fluororesin membrane supported by a layer of spun-bonded synthetic media on the upstream and downstream side.

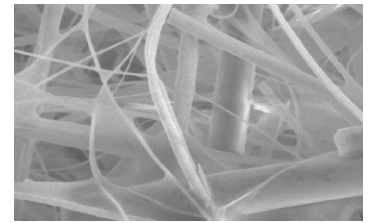

(10,000x)

- Available efficiencies:
 - 99.99% @ 0.3um/99.95% @ MPPS (H13)
 - 99.995% @ 0.3um/99.995% @ MPPS (H14)
- Designed for ultra-high particulate loading, including oil-based test aerosols for Life Science applications
- Compatible with photometric test methods

MEGAcel II ePTFE Media:

Single layer of expanded PTFE supported by a layer of spun-bonded synthetic media on the upstream and downstream side.

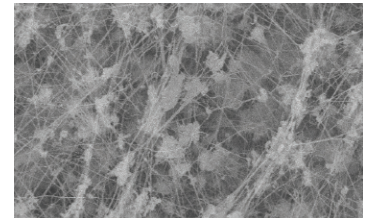

(10,000x)

- Available efficiencies:
 - 99.9995% @ MPPS (U15)
 - 99.99995% @ MPPS (U16)
 - 99.999995% @ MPPS (U17)
- Standard for Microelectronic and Tool Market applications
- Compatible with discrete particle counters (DPC) testing

Performance Information – Standard Sizes

Nom. Size	Model	Casing Dimension (Less Filter) (L x W x H) (+Hanging Tabs) in/mm	Weight lbs/kg	Voltage (V)	Filter Type & Nom. Pack Depth	Filter Performance	Power (W)	Noise dB(A) @ 90FPM
2x2	AFUA-EC3T-600x600-1-0-0	23-5/8" x 23-5/8" x 13-3/4" (+1-7/8") 600 x 600 x 349 (+40)	25 / 11	115	Glass, 2"	99.995% / H14	91	50 ± 1
					eFRM, 2"	99.995% / H14	72	48 ± 1
					ePTFE, 1.5"	99.9995% / U15	82	50 ± 1
	AFUA-EC3T-600x600-2-0-0			277	Glass, 2"	99.995% / H14	72	50 ± 1
					eFRM, 2"	99.995% / H14	70	47 ± 1
					ePTFE, 1.5"	99.9995% / U15	76	50 ± 1
2x4	AFUA-EC4T-600x1210-1-0-0	23-5/8" x 47-5/8" x 13-3/4" (+1-7/8") 600 x 1210 x 349 (+40)	58 / 26	115	Glass, 2"	99.995% / H14	152	56 ± 1
					eFRM, 2"	99.995% / H14	113	54 ± 1
					ePTFE, 1.5"	99.9995% / U15	124	56 ± 1
	AFUA-EC4T-600x1210-2-0-0			277	Glass, 2"	99.995% / H14	144	55 ± 1
					eFRM, 2"	99.995% / H14	106	52 ± 1
					ePTFE, 1.5"	99.9995% / U15	119	54 ± 1
4x4	AFUA-EC4T-1210x1210-1-0-0	47-5/8" x 47-5/8" x 13-3/4" (+1-7/8") 1210 x 1210 x 349 (+40)	71 / 32	115	Glass, 2"	99.995% / H14	269	59 ± 1
					eFRM, 2"	99.995% / H14	230	61 ± 1
					ePTFE, 1.5"	99.9995% / U15	244	60 ± 1
	AFUA-EC4T-1210x1210-2-0-0			277	Glass, 2"	99.995% / H14	160	58 ± 1
					eFRM, 2"	99.995% / H14	217	57 ± 1
					ePTFE, 1.5"	99.9995% / U15	230	57 ± 1

- 1) FFU test references: IEST RP-CC-036.1-2014, JG/T 388-2012, GB/T1236-2000, GB 9068-1988.
- 2) The noise level is measured 1.5m (~60") directly below the unit outlet. Noise, dB(A), measured at ESP = 0.36 in. w.g.
- 3) Different sizes can be provided according to customer needs.
- 4) The above performance parameters are obtained by measurements made in a laboratory. On-site performance depends on site conditions.

MEGAcel® II eFRM/ePTFE vs. Glass Filter Performance

Energy Efficiency of AstroFan Paired with Membrane Filters

Life Science Applications: eFRM vs Glass

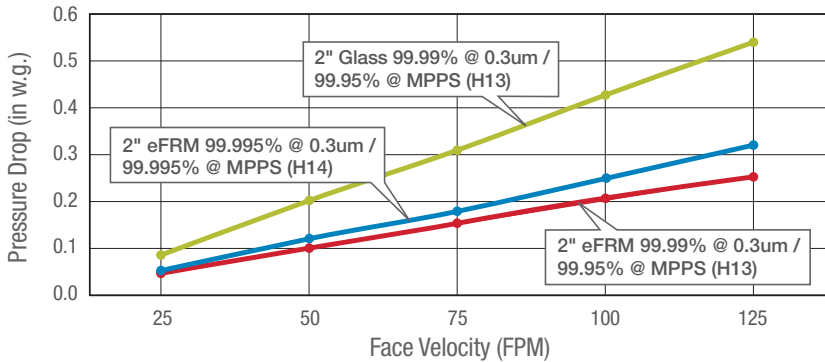

Microelectronic Applications: ePTFE vs Glass

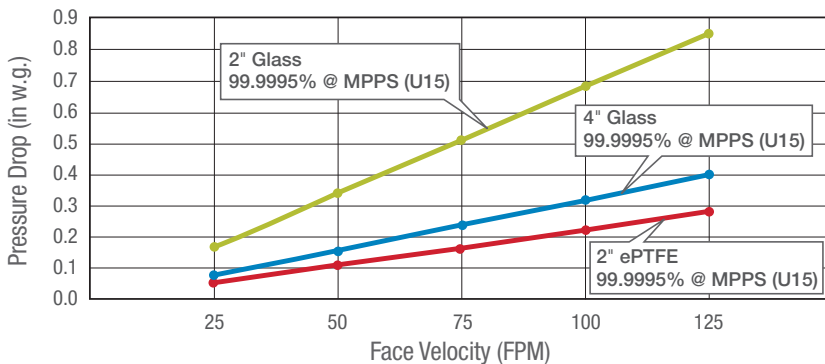

Checkbox Submittal

PART NUMBER EXAMPLE: AFUA-EC4R-600X1210-2-00-0-BS-H14E

REV	ECN#	DESCRIPTION	BY	DATE
		TERMINOLOGY CHANGES, INCREASE MINIMUM SIZE, UPDATE TOP VIEW	JWH	8/26/20

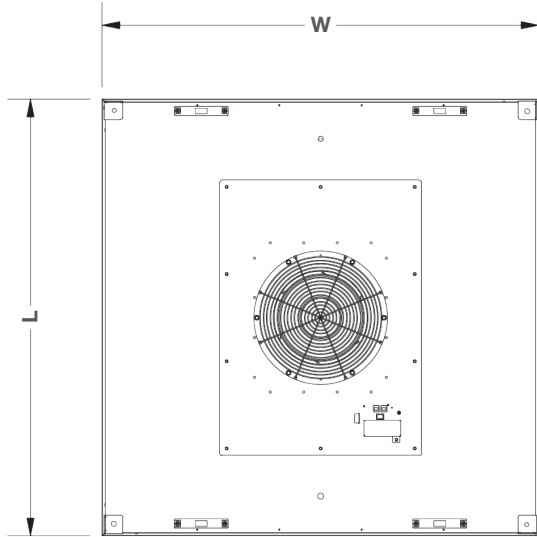

Top View

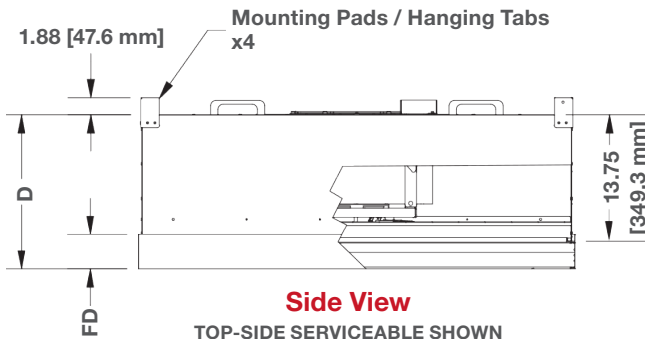

Side View
TOP-SIDE SERVICEABLE SHOWN

* FD = TSS FILTER DEPTH OR RSR ADAPTOR DEPTH.
PLEASE NOTE HOUSING SITS INSIDE TSS/RSR FRAME

Frame Style	FD	D
TSS	3.73 [94.9]	16.75 [425.5]
RSR	4.73 [120.2]	17.75 [451.0]

CUSTOMER APPROVAL

DRAWINGS MUST BE SIGNED IN ORDER TO PROCEED WITH PRODUCTION.
[] APPROVED [] APPROVED AS NOTED [] NOT APPROVED

SIGNATURE: _____ DATE: _____

COMMENTS: _____

QUOTE NO: _____

UNLESS OTHERWISE SPECIFIED
DIMENSIONS ARE IN INCHES
TOLERANCES ARE:

FRACTIONS X/X	±1/8
DECIMALS X.XX	±0.13
DIAGONALS	±1/8



TITLE: ASTROFAN

THE INFORMATION CONTAINED ON THIS DRAWING IS PROPRIETARY TO AAF FLANDERS AND MAY NOT BE USED, REPRODUCED NOR TRANSMITTED TO OTHER PARTIES WITHOUT EXPRESSED WRITTEN CONSENT OF AAF FLANDERS.

DRAWN BY	CHECKED BY	APPROVED BY	SHEET	SHEET SIZE	SCALE
jholland	T. ONEAL	MAK	1 OF 1	A	1 / 20
DATE	DATE	DATE			REV
1/13/2020	9/1/2020	9/1/2020			D
DRAWING NUMBER			600-00018		

Material Type

- AFUA = Aluminum
- AFUS = Stainless Steel

Configuration

CHOOSE SERVICEABLE SIDE

- EC = Electronically Commutated Motor
- R = Room-Side Replaceable/Serviceable*
- T = Top-Side Serviceable**

* Aerosol Injection Provided Standard
** Requires Filter w/ Centerboard Port(s) for Aerosol/Pressure Measurement

Standard 1-1/2" T-Bar Sizes

- 2x2 600x600 mm (23 5/8" x 23 5/8")
- 2x4 600x1210 mm (23 5/8" x 47 5/8")
- 4x4 1210x1210 mm (47 5/8" x 47 5/8")

Custom Unit Size (Width x Length) mm

Width Range = 560-1220 mm
Length Range = 560-1220 mm



Unit Size is Based on TSS or RSR Filter Frame to Grid Interface

Unit Voltage

- 1 = 100-130 Voltage Range AC 50/60 HZ
- 2 = 200-277 Voltage Range AC 50/60 HZ

Options

- 0 = None
- A = Powder Coated Housing White
- B = Insulated Housing 2" Foilback
- 0 = None
- A = Round Duct Collar
- B = Rec Duct Collar/Pre-Filter Frame*

* Required for Pre-Filter/or AMC Filtration Ordered Separately

Accessories

- 0 = None
- A = Double Poly Bagged

Filter Loading

- T = Top Load Filter
- TC = Top Load w/ Test Port
- BA* = Bottom Load w/ Aluminum Screen
- BS* = Bottom Load w/ Stainless Screen
- BP* = Bottom Load w/ Painted Screen

* Grille Ships with RSR Adaptor

Filter Options

- H13E = H13 / 99.99% @ 0.3 µm eFRM
- H14E = H14 / 99.995% @ MPPS eFRM
- U15E = U15 / 99.9995% @ MPPS ePTFE
- H13G = H13 / 99.99% @ 0.3 µm GLASS
- H14G = H14 / 99.995% @ MPPS GLASS
- U15G = U15 / 99.9995% @ MPPS GLASS

AstroFan™ EC FFU

Model Number System

AFUA – EC4R – 600 x 1210 – 2 – 00 – 0 BS – H14E

(1) (2) (3) (4) (5) (6) (7) (8)

(1) PRODUCT TYPE	(2) CONFIGURATIONS	(3) UNIT SIZE	(4) UNIT VOLTAGE	(5) OPTIONS	(6) ACCESSORIES	(7) FILTER LOADING	(8) FILTER OPTIONS
------------------------	-----------------------	---------------------	------------------------	----------------	--------------------	--------------------------	--------------------------

<p>(1) Product Type: Example: AFUA-EC4R-600x1210-2-00-0 BS-H14E AFUA - AstroFan Aluminum AFUS - AstroFan Stainless Steel</p>	<p>(5) Options (multiple items can be chosen): 0 = None 1 = Powder Coated Housing, White 2 = Insulated Housing, 2" Foilback</p> <p>0 = None A = Round Duct Collar (2x2-10", 2x4-12") B = Rec Duct Collar / Pre-Filter Frame* * Required for Pre-filter or AMC filtration (ordered separately).</p>						
<p>(2) Configuration (see Standard Size Configurations below): EC = Electronically Commutated Motor</p> <p>3 = Max Flow 1200 CFM / 2040 CMH 4 = Max Flow 2000 CFM / 3400 CMH</p> <p>R = Room-Side Replaceable/Serviceable* T = Top-Side Serviceable**</p> <p>* Aerosol injection provided standard. ** Requires filter w/ centerboard port(s) for aerosol/pressure measurement.</p>	<p>(6) Accessories: 0 = None A = Double Poly Bagged</p>						
<p>(3) Unit Size (Width x Length) mm: EC3 Width Range = 580-720 mm EC3 Length Range = 580-1070 mm EC4 Width Range = 580-1220 mm EC4 Length Range = 915-1220 mm</p>	<p>(7) Filter Loading: T = Top Load Filter TC = Top Load w/ Test Port BA* = Bottom Load w/ Aluminum Grille BS* = Bottom Load w/ Stainless Grille BP* = Bottom Load w/ Painted Grille</p> <p>* Grille ships with RSR Adaptor.</p>						
<p>(4) Unit Voltage: 1 = 100-130 Voltage Range AC 50/60 Hz 2 = 200-277 Voltage Range AC 50/60 Hz</p>	<p>(8) Filter Options: H13E = H13 / 99.99% @ 0.3um eFRM H14E = H14 / 99.995% @ MPPS eFRM U15E = U15 / 99.9995% @ MPPS ePTFE H13G = H13 / 99.99% @ 0.3um Glass H14G = H14 / 99.995% @ MPPS Glass U15G = U15 / 99.9995% @ MPPS Glass</p>						
Standard Sizes (1-½" T-Bar)				Standard Sizes (2" T-Bar)			
2 x 2	23-5/8" x 23-5/8"	EC3	600 x 600	2 x 2	23-1/8" x 23-1/8"	EC3	587 x 587
2 x 4	23-5/8" x 47-5/8"	EC4	600 x 1210	2 x 4	23-1/8" x 47-1/8"	EC4	587 x 1197
4 x 4	47-5/8" x 47-5/8"	EC4	1210 x 1210	4 x 4	47-1/8" x 47-1/8"	EC4	1197 x 1197

Note: Filters ordered separately; however, it is good practice to supply a Filter Code with the AstroFan Model Number to ensure compatibility check.

AstroFan Specifications

1.0 Construction

1.1 Housing shall:

- 1.1.1 Be constructed of Aluminum or 304 SST.
- 1.1.2 Have hanging tabs/mounting pads on 4 corners.
- 1.1.3 Have handles.
- 1.1.4 Have a protection grid/finger guard on the fan inlet.

1.2 Fans:

- 1.2.1 Motors shall be Electronically Commutated (EC).
- 1.2.2 Supplied as backward curved/inclined wheel.

1.3 Controls Shall:

- 1.3.1 Operate on MODBUS RTU protocol platform.
- 1.3.2 Include BACNET gateway compatibility as an option.

2.0 Performance and Testing

2.1 Each unit shall be fully tested.

2.2 Each unit shall be serialized allowing for full traceability to the specified test procedure. Test reports provided upon request.

MEGAcel® II ePTFE / eFRM Specifications*

1.0 Scope

1.1 Filters shall be expanded polytetrafluoroethylene (ePTFE) mini-pleat ULPA or expanded FlouroResin Media (eFRM) HEPA grade.

1.2 Sizes and specific configuration shall be noted on drawings, schedules, or other supporting documents.

2.0 Construction

2.1 Filtration media shall be produced by the filter manufacturer and shall consist of an ePTFE or eFRM membrane and shall be boron-free. Glass fiber media is not allowed. eFRM media shall be compatible with industry standard validation and testing methodologies using an acceptable oil aerosol agent (i.e. PAO).

2.2 The filter frame shall be clear anodized extrude aluminum and shall be designed for use in gasket or gel fluid seal systems.

2.3 Gasket filters shall have a 1/4" thick x 3/4" wide dovetailed urethane sponge gasket.

2.4 Filter fluid seal must be comprised of a two component high molecular weight, polysiloxane elastomeric sealant and be self-leveling.

- 2.4.1 Fluid seal material shall be characterized for all salient mechanical, physical, and chemical properties such as Hardness/Penetration, Tack, and Migration of free silicone (i.e. Blot Plot Testing).

2.4.2 Fluid seal material shall be characterized for chemical resistance to known industry accepted decontamination agents, cleaning agents, and filter testing reagents.

2.4.3 Fluid seal material shall be characterized for chemical compatibility to all materials in contact during manufacturing including gloves, tools, mixing equipment, dispensing equipment, and packaging materials, as well as potential airborne contaminants and poisons.

2.4.4 Fluid seal material shall demonstrate resistance to accelerated life cycle testing.

2.4.5 Fluid Seal shall withstand knife-edge insertion to partial depth without complete depth cutting or full length splitting.

2.5 Extrusion shall have a continuous trough around the perimeter of the filter and shall be filled at the factory.

2.6 The media pack shall be sealed on all sides with a solid, fire-retardant, phosphorus-free polyurethane sealant to form a leak-free bond between the media pack and the filter frame.

2.7 Manufacturing shall take place in an ISO 7 cleanroom. Packaging shall be in an ISO 6 cleanroom.

3.0 Performance

3.1 Each eFRM/ePTFE filter shall have a minimum overall efficiency and maximum clean resistance per schedule below:

Media Type	Nominal Pack Depth	Efficiency	Max. Initial ΔP
eFRM	2.0"	99.99% on 0.3µm	0.25" w.g.
eFRM	2.0"	99.995% on 0.12µm	0.30" w.g.
ePTFE	2.0"	99.9995% on 0.12µm	0.26" w.g.
ePTFE	1.5"	99.9995% on 0.12µm	0.44" w.g.

3.2 Each filter shall be factory scanned in accordance with IEST-RP-CC034 or EN1822

3.3 Each filter shall have a unique label indicating filter size, lot number, unique serial number, model number, tested efficiency, pressure drop at volumetric test airflow, and UL compliance.

3.4 Filters shall be Underwriters Laboratories (UL) Standard 900 classified.

*Microglass HEPA/ULPA filter options available upon request.

AstroDrive™ FFU Controls

AstroDrive 100 – Handheld Control

- Portable control unit
- Clear and simple menu-guided interface
- Individual controls or up to 100 FFUs in a line
- ebmBUS or MODBUS interface
- Battery powered with Mini-USB - battery charge



AstroDrive 200 – Wall-Mount Control

- Stand-alone monitoring and control unit
- Up to 200 EC-fans
- ebmBUS or MODBUS interface
- Clear and simple menu guide
- IP65-wall-mounted
- Includes digital inputs/outputs
- Includes dry contact points

